

GCSE Physics

Electricity and Circuits

Energy

Electricity

Particle Model of Matter

Radioactivity

Circuit Symbols
Circuit Diagram
Charge, Current, Resistance and
Potential Difference
Voltage-Current Graph of
Resistor, Filament Bulb and diode
Series Circuit
Parallel Circuit
Main electricity
Power
Energy Efficiency
National Grid
Static Electricity

CIRCUIT SYMBOLS

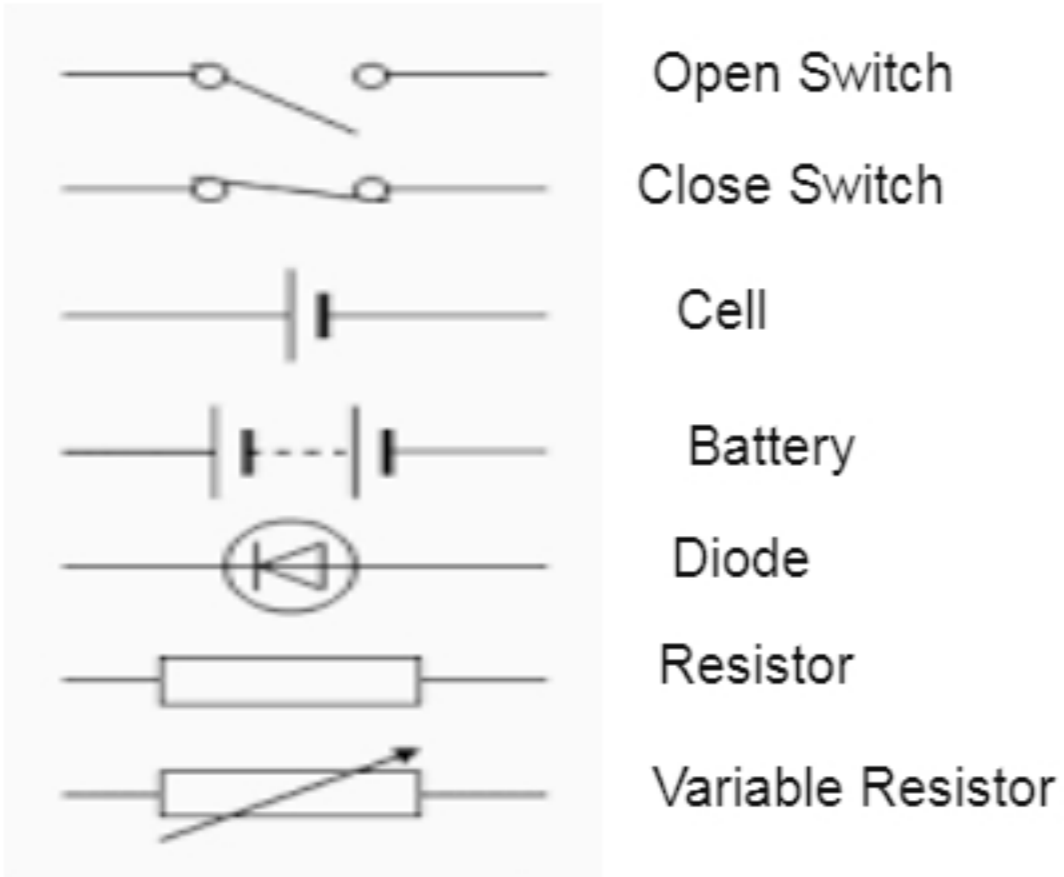

Light Emitting Diode

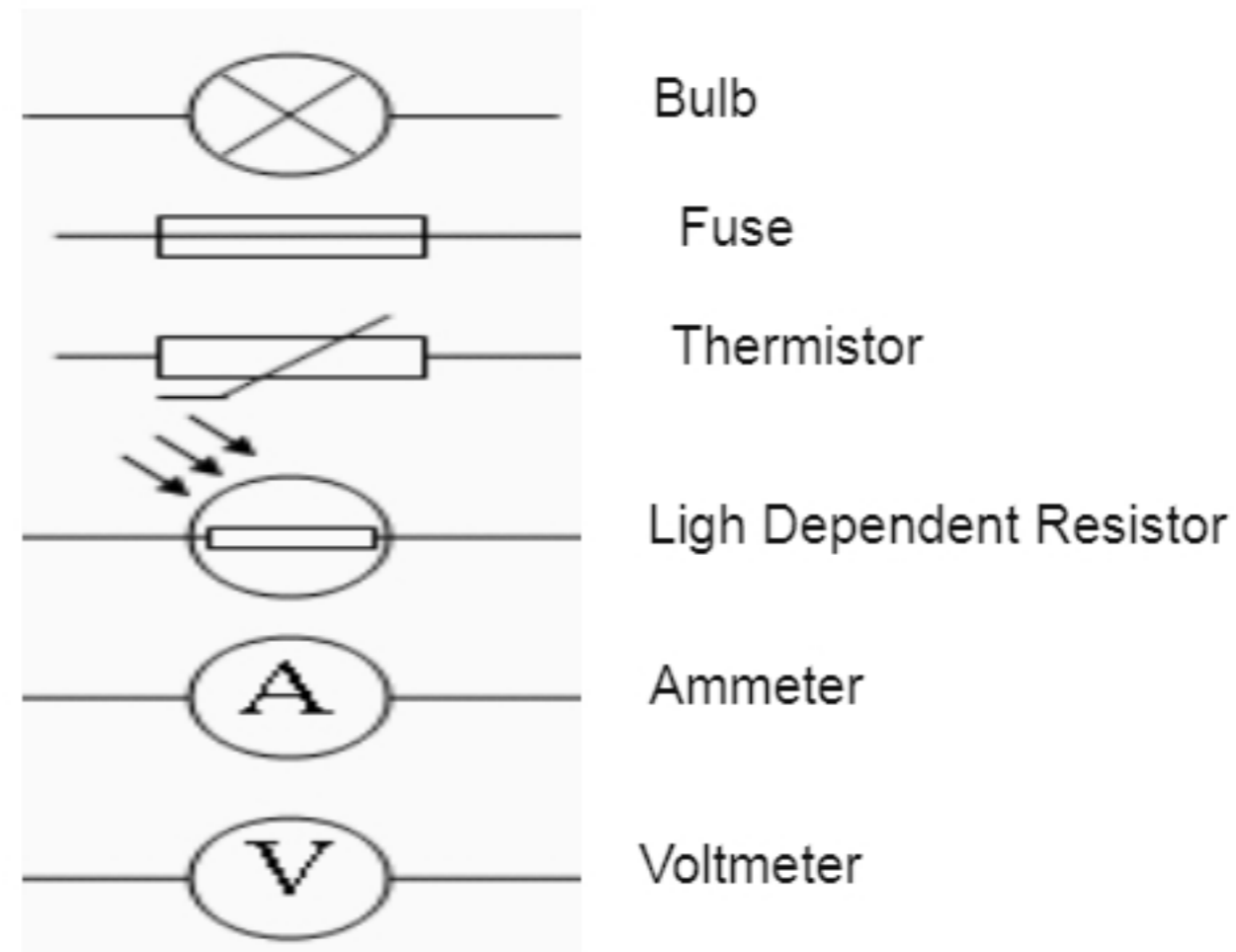

Source: Wikimedia commons

CIRCUIT DIAGRAM

Draw a circuit diagram with a battery, bulb and a switch.
How will you measure the current and potential Difference of the Circuit ?

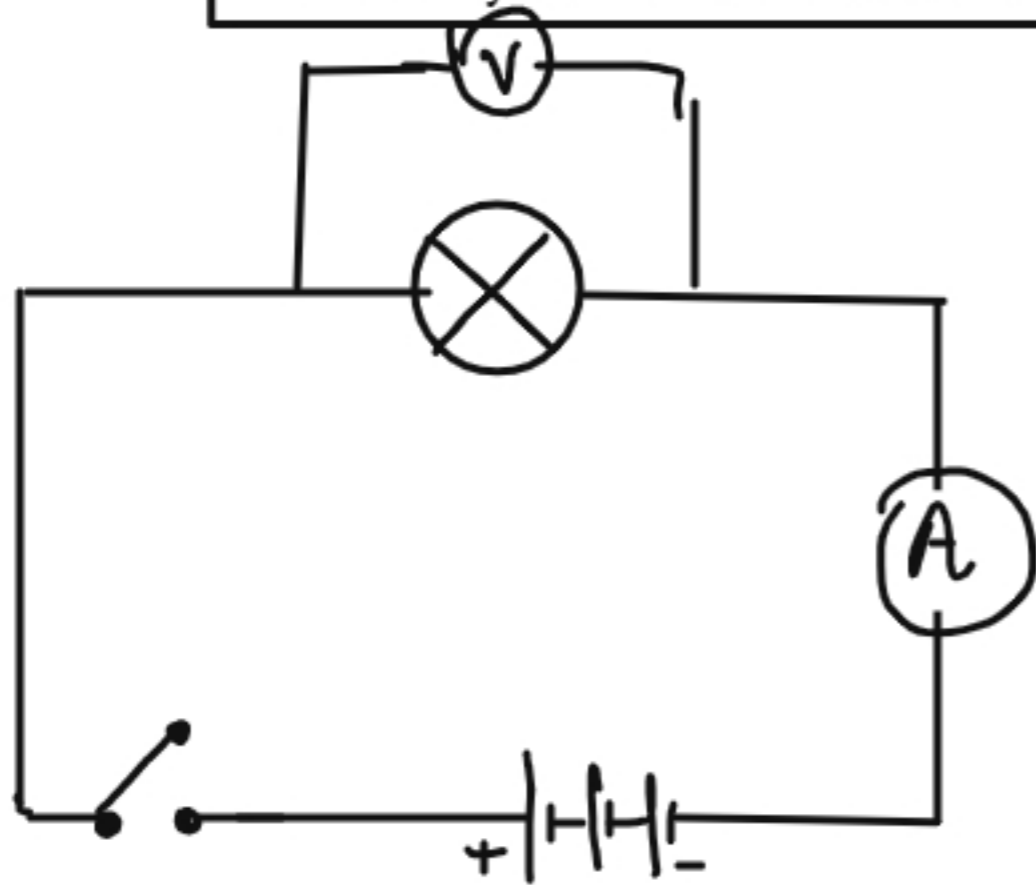

 Device used to measure the current in the circuit
(always connected in series)

 Device used to measure the voltage in the circuit
(always connected in parallel)



CURRENT, POTENTIAL DIFFERENCE AND RESISTANCE

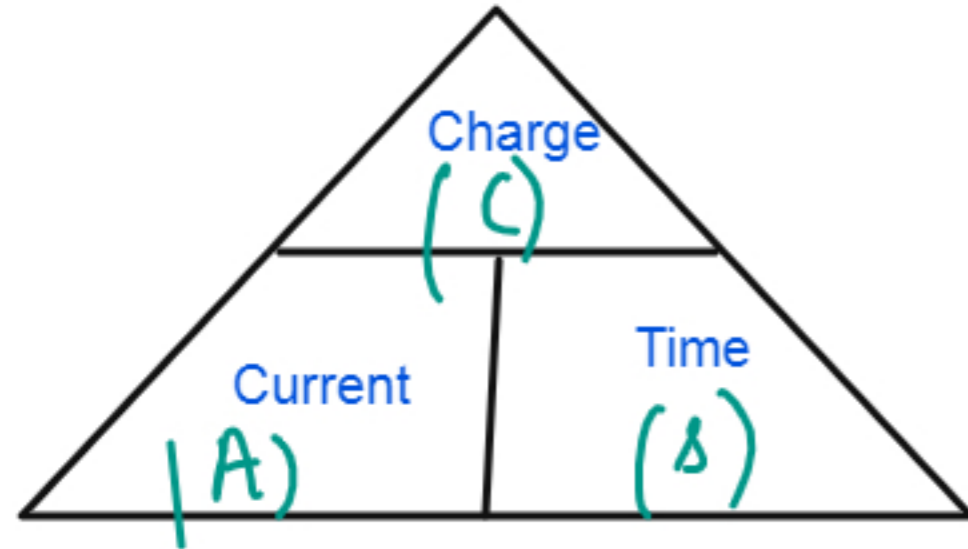

$$1A = 1Cs^{-1}$$

Current is the rate of flow of charge measured in Ampere.
One Ampere is the current flowing when one coulomb of charge flows through one second.

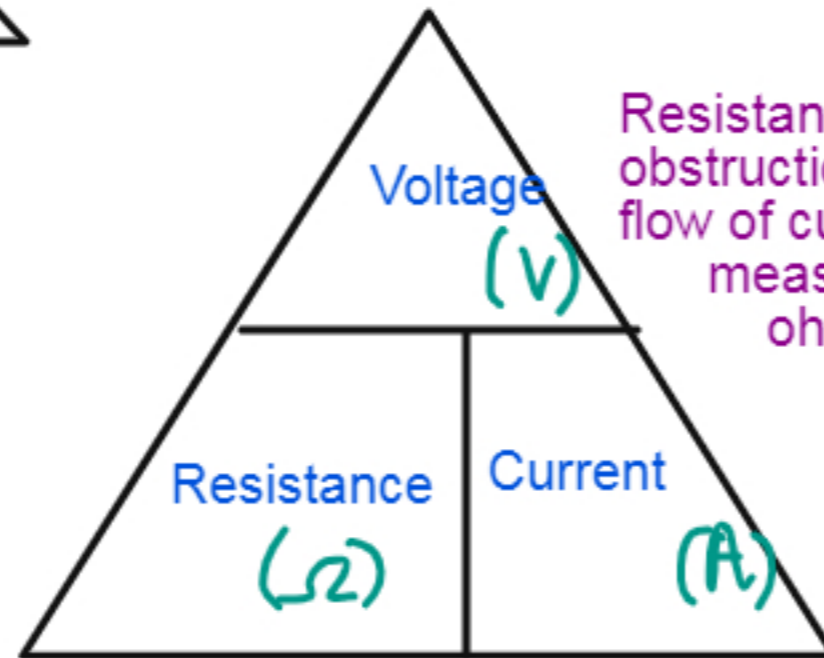

Resistance is the obstruction to the flow of current measured in ohms .

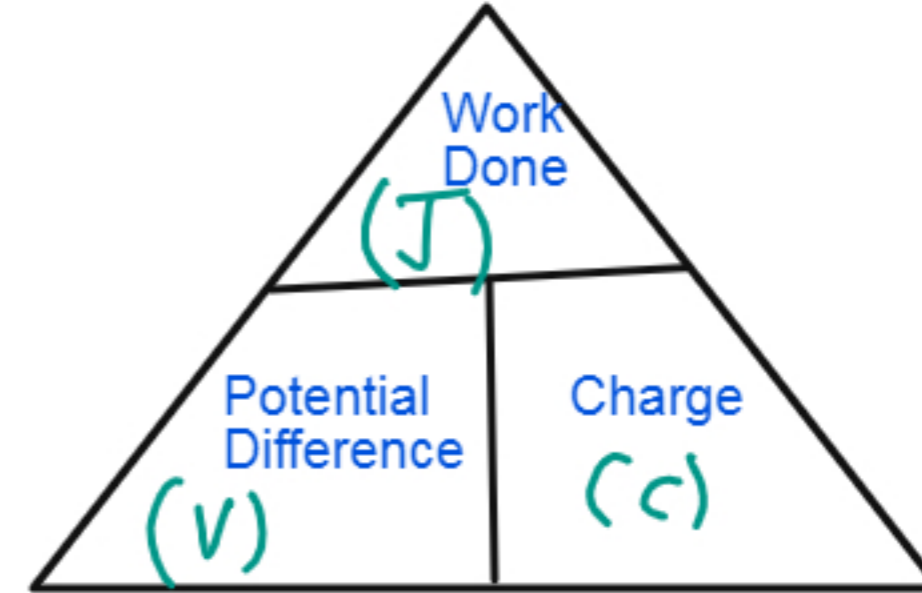

Potential difference measured in Volts is the work done per unit charge.

$$1V = 1Jc^{-1}$$

One volts is the potential difference when 1 J of energy is transferred per coulomb of charge.



EXPERT GUIDANCE

www.expertguidance.co.uk

EXAMPLES

Q1 Calculate the current flowing when 4 C of charge flows for 2 minutes ?

$$I = \frac{Q}{t} = \frac{4}{2 \times 60} = 0.033 \text{ A}$$

Q2 Calculate the energy transferred when 2 V of potential difference creates a charge of 2 C

$$E = V \times Q = 2 \times 2 = 4 \text{ J.}$$

Q3 Calculate the resistance of the circuit when 4V of potential difference produces a current of 2 A.

$$R = \frac{V}{I} = \frac{4}{2} = 2 \Omega.$$

Q4 Calculate the charge when 5A of current flows for 5 minutes

$$Q = I \times t = 5 \times 5 \times 60 = 1500 \text{ C.}$$

Q5 Calculate the potential difference when 10 J of work done is done to move the charge of 5 C.

$$V = \frac{E}{Q} = \frac{10}{5} = 2 \text{ V}$$

www.expertguidance.co.uk
mahima.laroyia@expertguidance.co.uk
+447448352272

VOLTAGE-CURRENT GRAPH

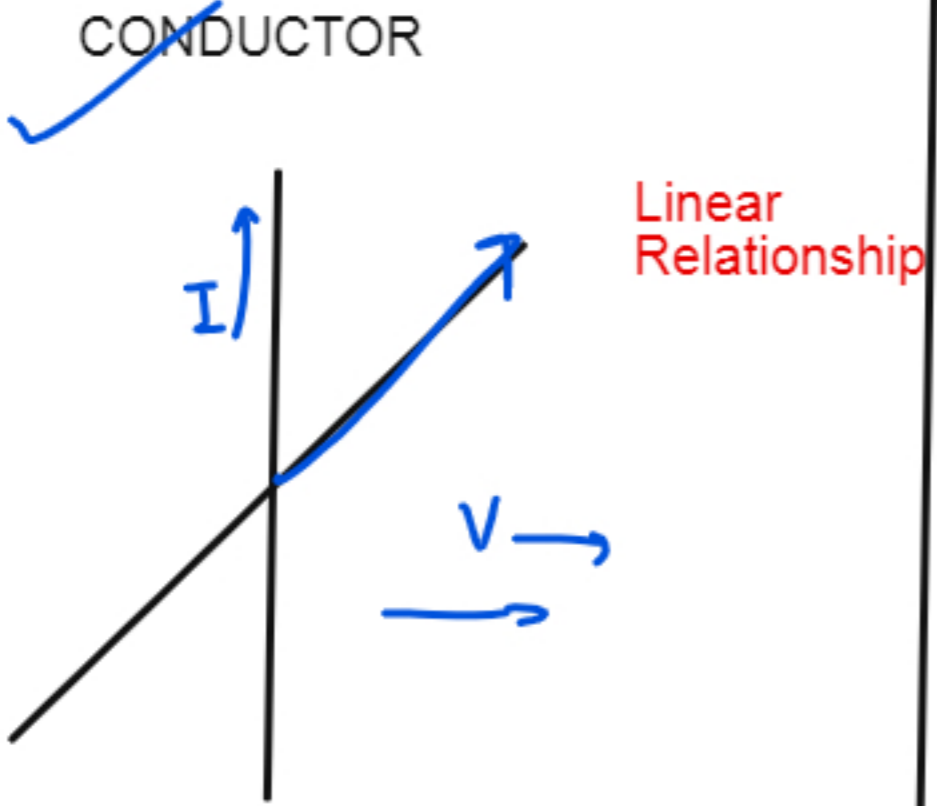

As the voltage increases, the current increases.
The resistance is constant.

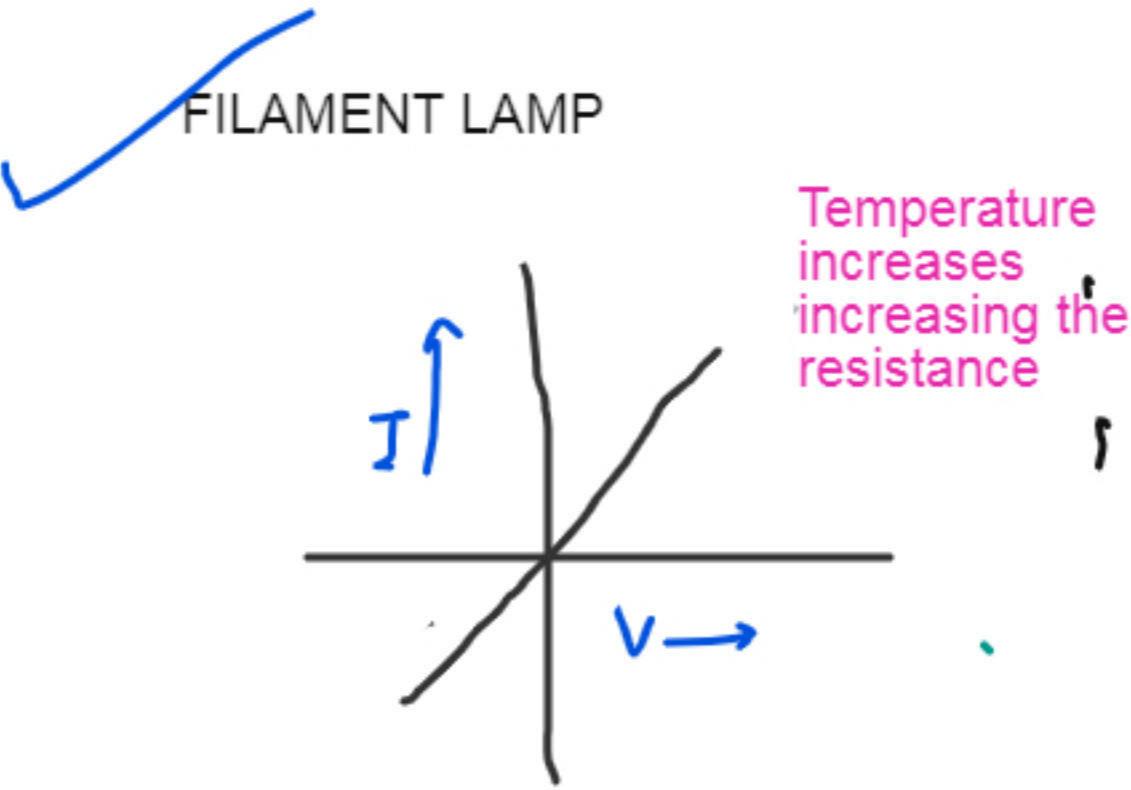

As the voltage increases, the current increases at the start but after that bulb gets heated and increase in temperature increases resistance so the current do not increases and the graph curves.

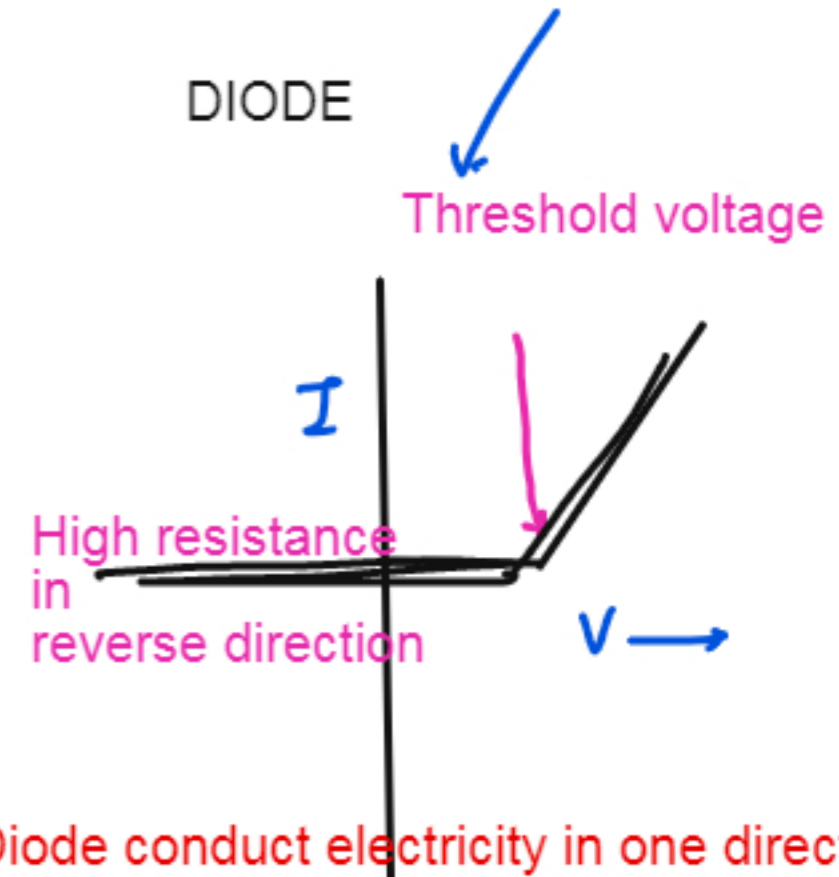

Diode conduct electricity in one direction. In reverse direction, the resistance is too high so no current flows. When it reaches a threshold voltage, the current starts to increases then linearly.

SERIES AND PARALLEL CIRCUITS

SERIES CIRCUIT

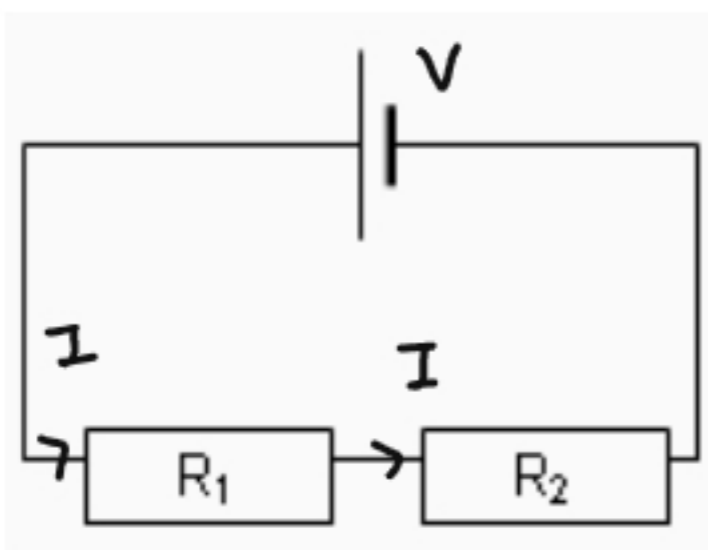

Total Resistance is greater than individual = $R_1 + R_2 = R_{total}$

Current Across each component is the same = $\frac{V_{(total)}}{R_{(total)}} = I$

Voltage gets divided between each component

$$V_1 = IR_1 \quad V_2 = IR_2$$

PARALLEL CIRCUIT

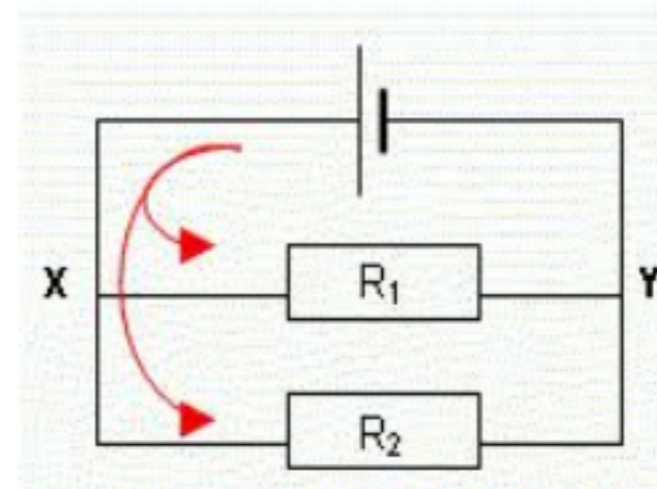

Total resistance is less than individual = $R_{total} = \frac{R_1 R_2}{R_1 + R_2}$

Voltage is same across each component = V

Current gets divided between the components

$$I_1 = \frac{V}{R_1} \quad I_2 = \frac{V}{R_2}$$



EXPERT GUIDANCE

www.expertguidance.co.uk



EXAMPLE OF SERIES AND PARALLEL CIRCUITS

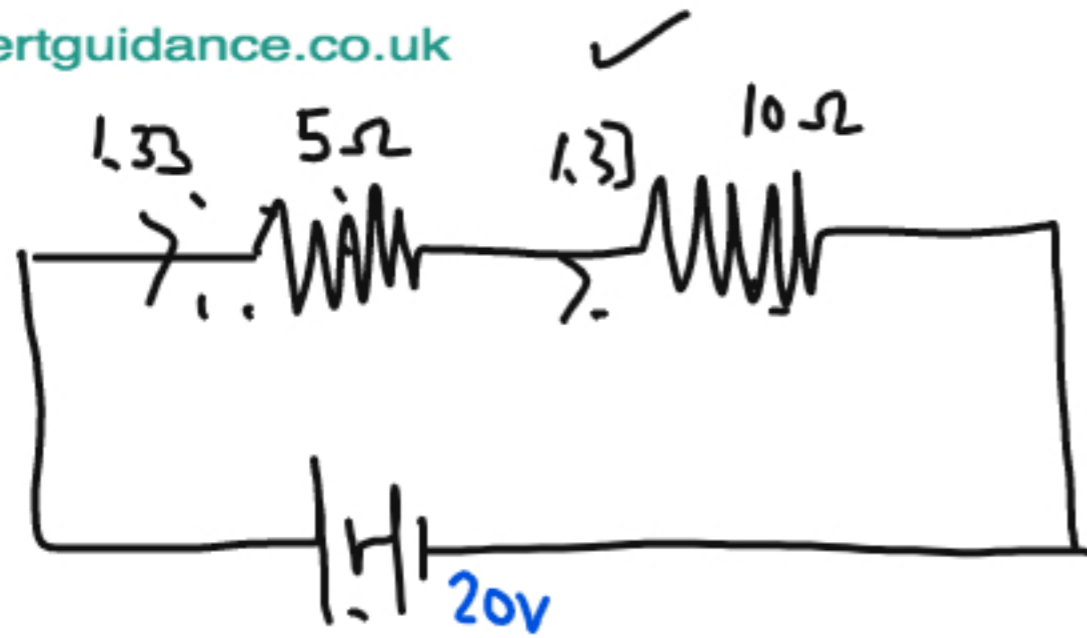

Total Resistance = $R_1 + R_2 = 15\Omega$

Voltage = 20 V (total)

Current = $\frac{20}{15} = 1.33 \text{ A}$

Voltage across 5 ohms = $1.33 \times 5 = 6.7 \text{ V}$

Voltage across 10 ohms = $1.33 \times 10 = 13.3 \text{ V}$

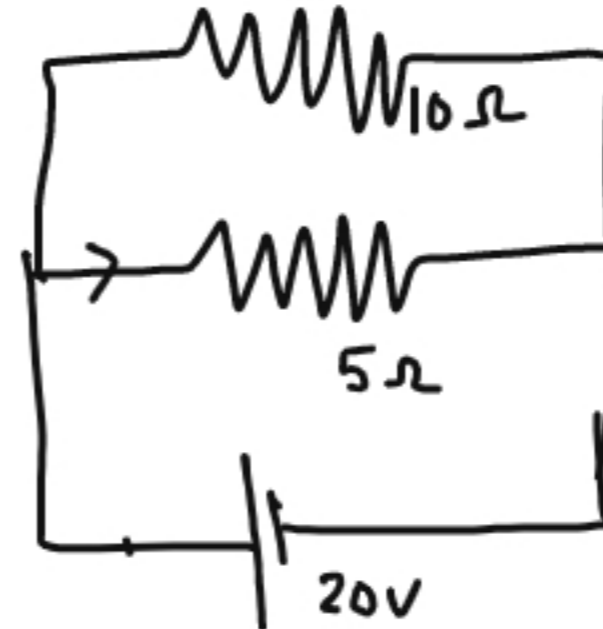

Total Resistance = $\frac{R_1 R_2}{R_1 + R_2} = \frac{50}{15} = 3.33$

Total Current = $\frac{V_{total}}{R_{total}} = \frac{20}{3.33} = 6 \text{ Amp}$

Current across 5 ohms = $\frac{20}{5} = 4 \text{ Amp}$

Current across 10 ohms = $\frac{20}{10} = 2$

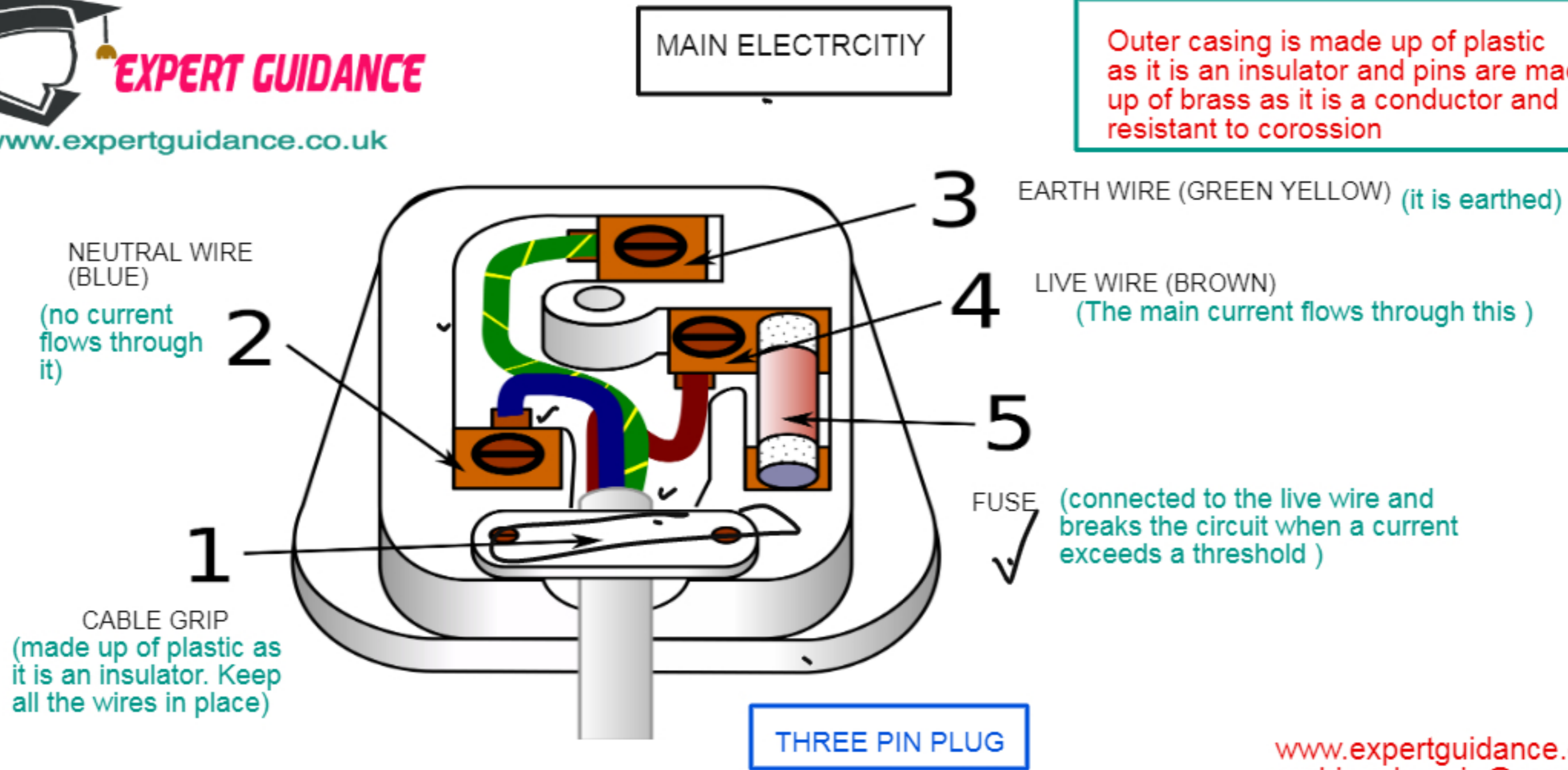

SOURCE: WIKIMEDIA COMMONS

www.expertguidance.co.uk
mahima.laroyia@expertguidance.co.uk
+447448352272

ELECTRIC POWER

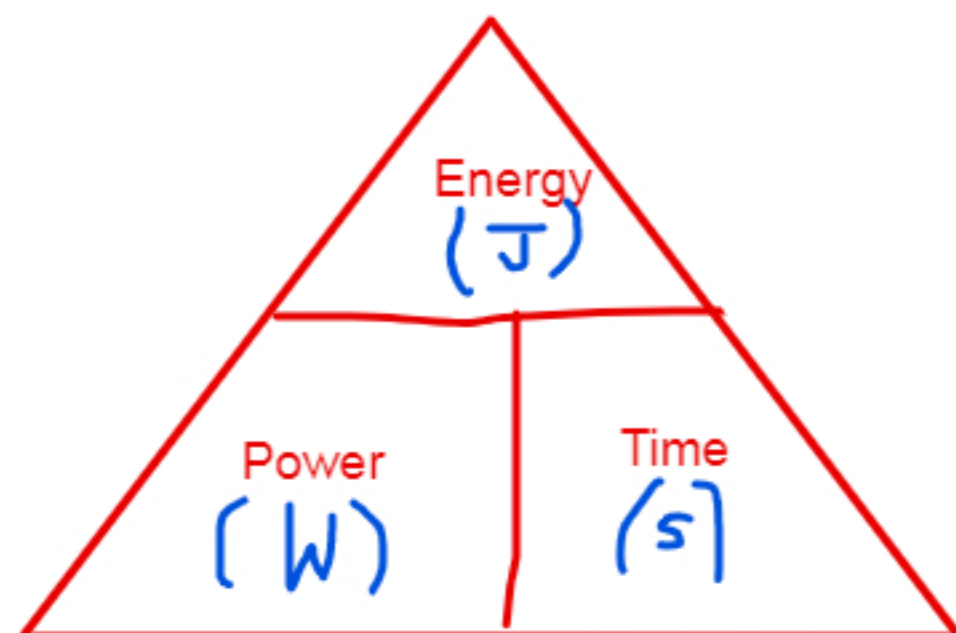

1 W is the power when 1 Joule of energy is transferred for one second.

$$\text{Electrical Power (P)} = V \times I$$

(voltage) \times (current)

$$P = I^2 \times R \quad [V = I \times R]$$

$$P = \frac{V^2}{R}$$

EXAMPLES

Q1 Calculate the current product by 200 W bulb if it generate a voltage of 10 V

$$P = I \times V$$

$$\frac{200}{10} = I = 20$$

Q2 Which is the best fuse for this appliance.

15, 20, 23A or 25A

$$P = V \times I$$

$$I = \frac{P}{V} = \frac{200}{10} = 20A$$

So the fuse of slightly greater than 20 A will be useful. So it has to be 23 A.

DIRECT AND ALTERNATING CURRENT

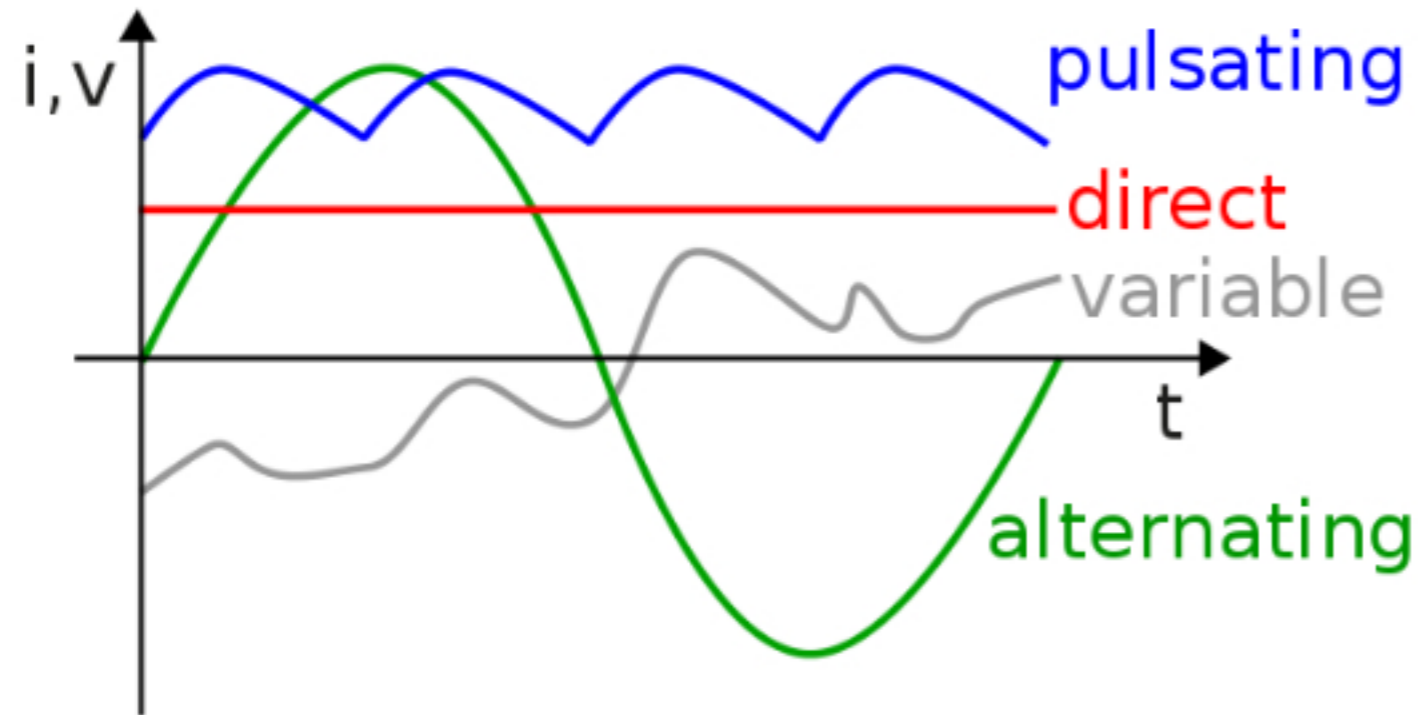

DIRECT	ALTERNATING
Current that flows in one direction.	Current that changes direction.
Current in cell and batteries.	Current in the mains supply.

www.expertguidance.co.uk
mahima.laroyia@expertguidance.co.uk
+447448352272

NATIONAL GRID

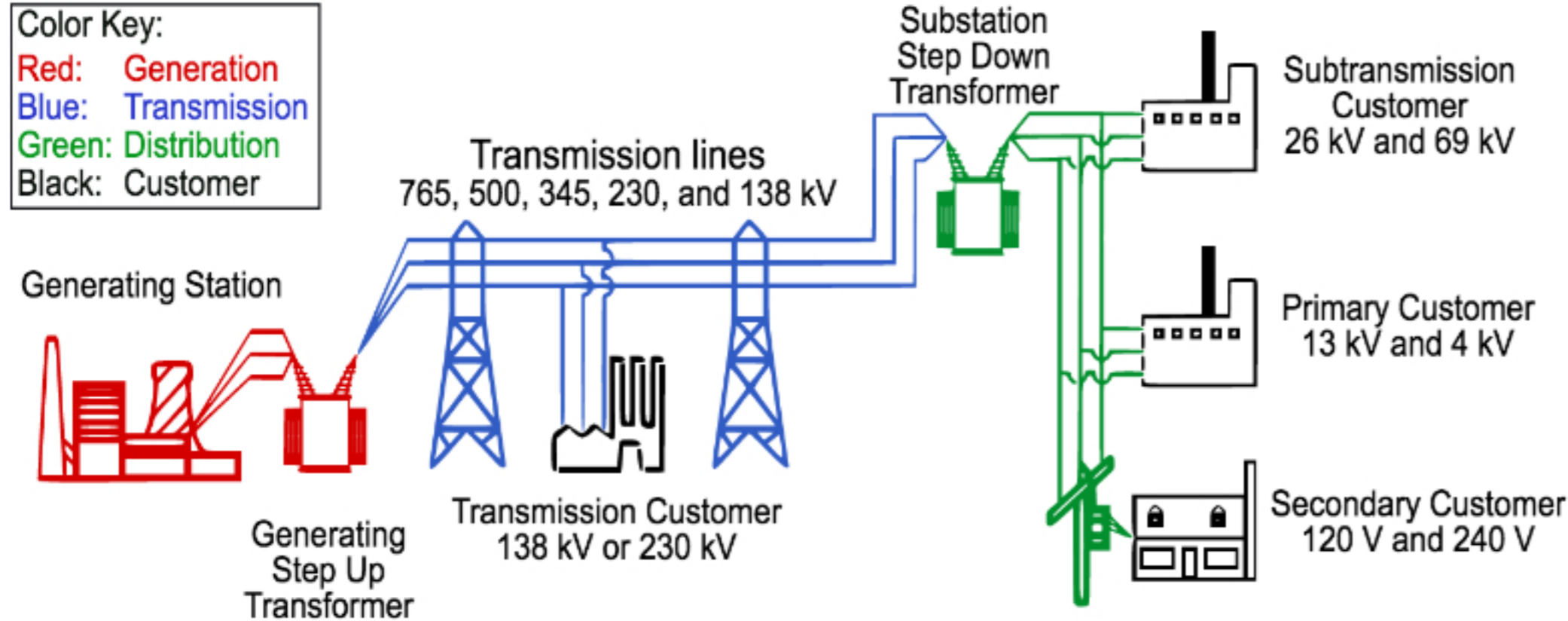

Source: Wikimedia Commons

A network of cable and transformers that transmits electricity from a power station to homes and buildings.

Step up transformer is used to increase the voltage for transmission. As higher voltage will have less current and so less loss of energy due to heating effect of current.

www.expertguidance.co.uk
 mahima.laroyia@expertguidance.co.uk
 +447448352272

STATIC ELECTRICITY

LIKE CHARGES REPEL and UNLIKE CHARGES ATTRACT EACH OTHER

Electricity due to the charge produced by rubbing.

Atom is neutral. Due to rubbing there is a movement of electrons from one surface to another.

The surface that loose electrons become negatively charged and the surface that gains electron become positively charged.

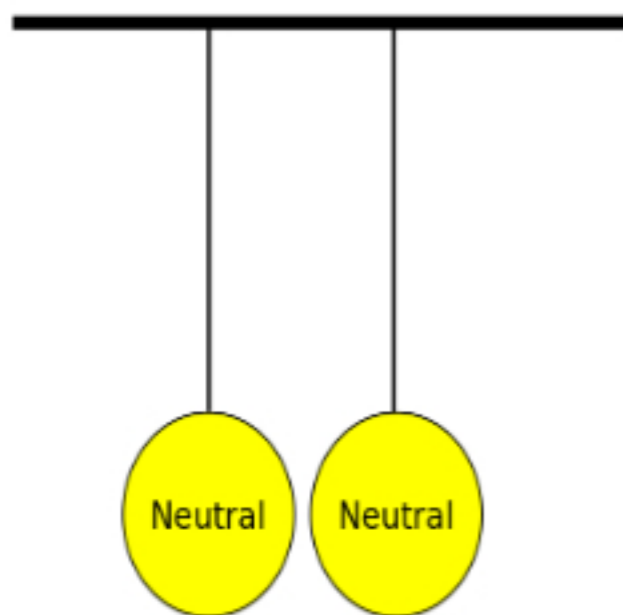

Neutral objects neither attract or repel.

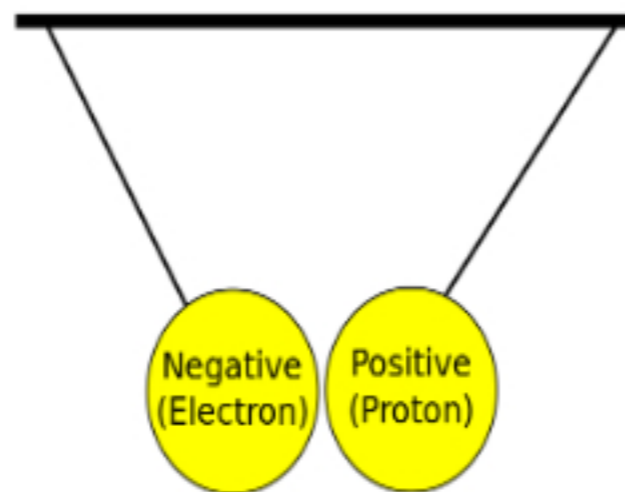

Oppositely charged objects attract.

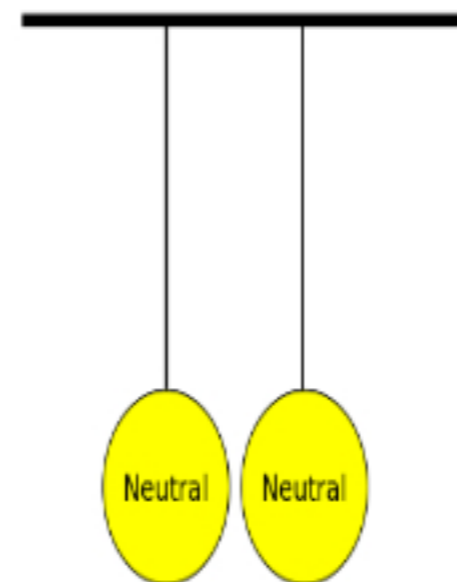

Neutral objects neither attract or repel.

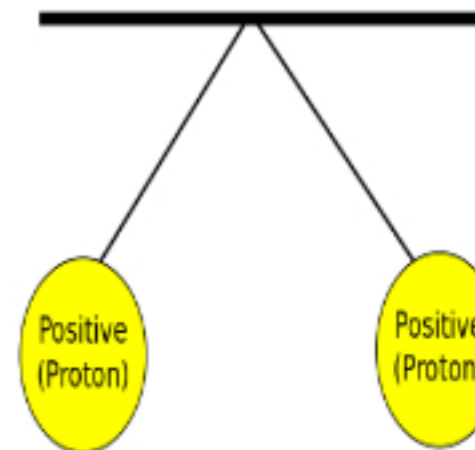

Objects with the same charge repel.

Source: Wikimedia Commons

ELECTRIC FIELDS

Electric Field of line always travel from positive to negative.

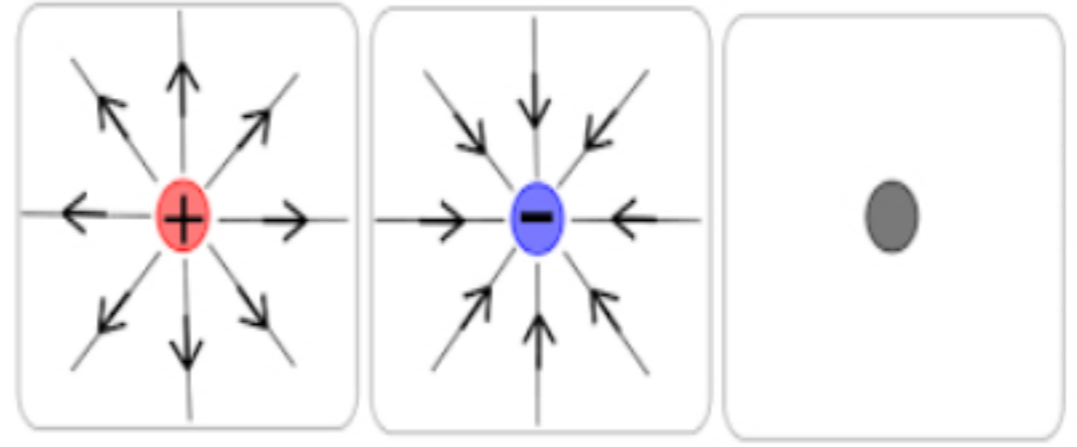
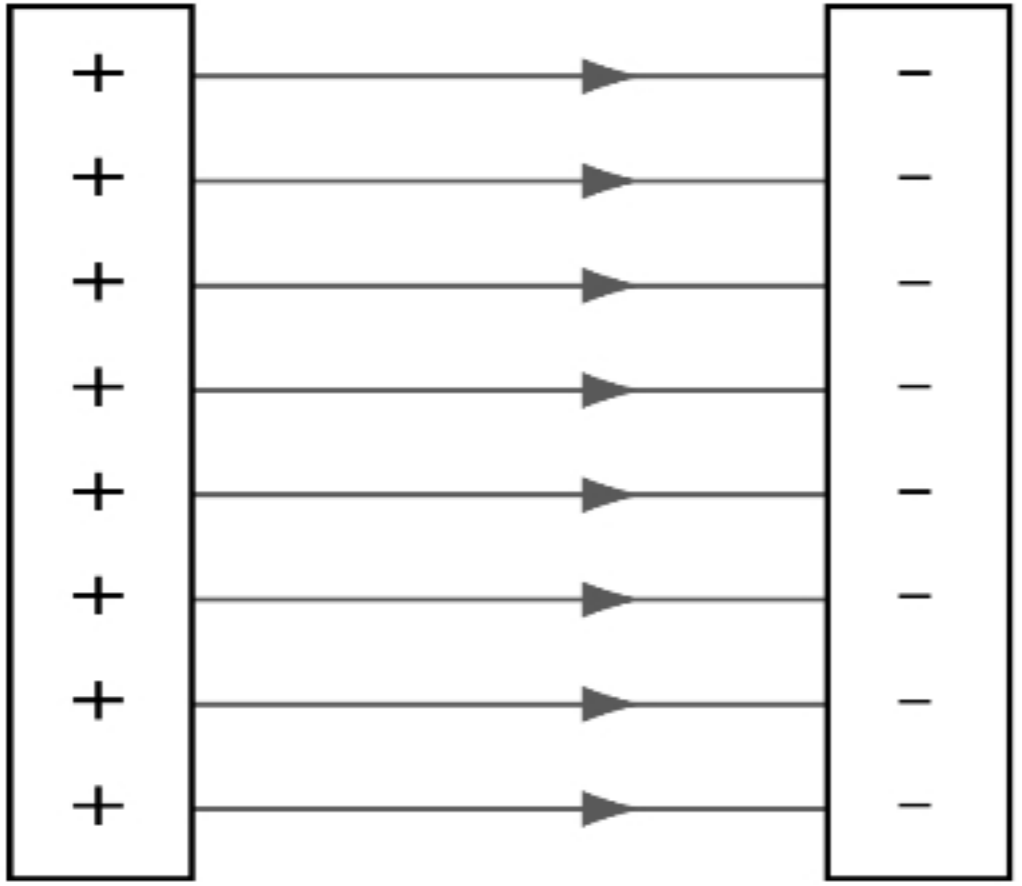

It is the area around a charge object where force of electricity can be felt.

www.expertguidance.co.uk
mahima.laroyia@expertguidance.co.uk
+447448352272



www.expertguidance.co.uk

Current
Charge
Thermistor
Resistor
Cell
Battery
Variable Resistor
Thermistor
Diode
Ammeter
Voltmeter
Potential Difference
Resistance
Direct Current
Alternating Current

KEY TERMS

Live Wire
Earth Wire
Neutral Wire
Fuse
Power
Efficiency

www.expertguidance.co.uk
mahima.laroyia@expertguidance.co.uk
+447448352272

TEST YOURSELF

Q1 Sketch and explain the Voltage and Current graph of

- a) Resistor
- b) Filament Lamp
- c) Diode

Q2 What are the components of a three pin plug

Q3 What is the voltage and frequency of UK Mains Supply ?

Q4 How do you calculate efficiency of an appliance

www.expertguidance.co.uk
mahima.laroyia@expertguidance.co.uk
+447448352272

VOLTAGE-CURRENT GRAPH



MAIN ELECTRCITIY

Outer casing is made up of plastic as it is an insulator and pins are made up of brass as it is a conductor and resistant to corossion

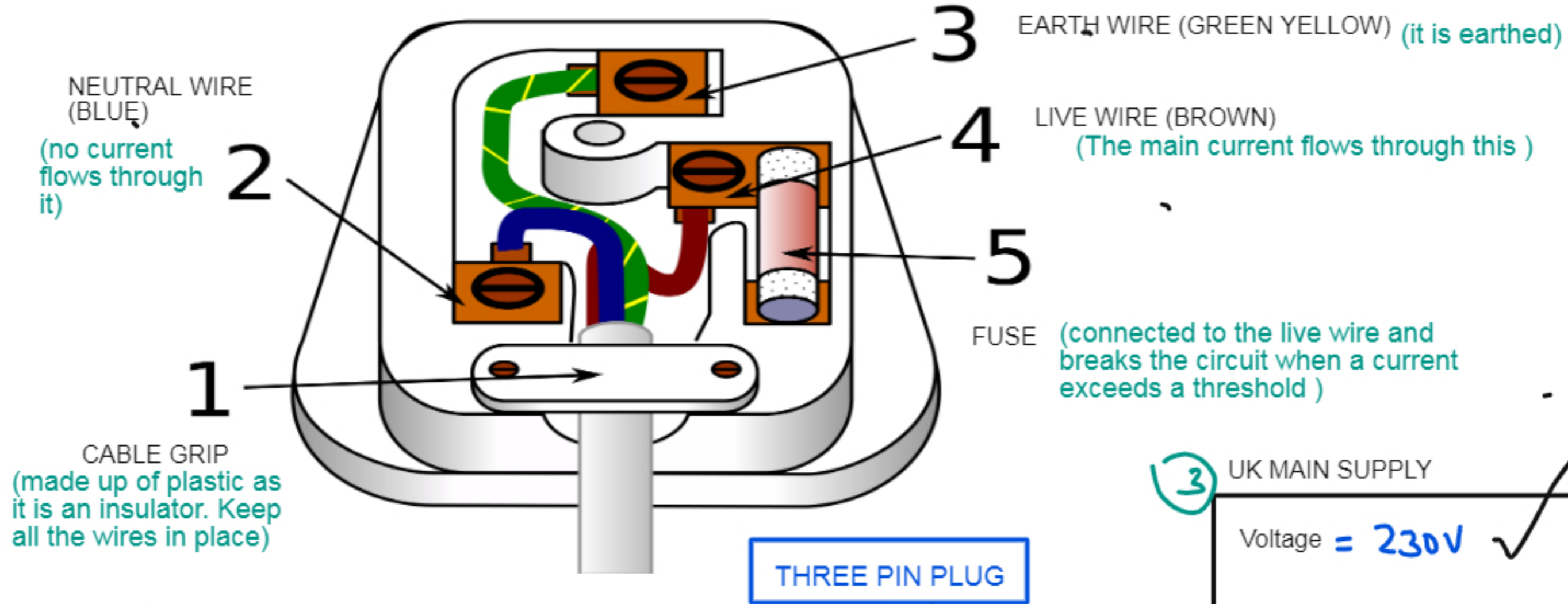

SOURCE: WIKIMEDIA COMMONS

③ UK MAIN SUPPLY

Voltage = 230V ✓

Frequency = 50 Hz ✓

④

$$\text{Efficiency} = \frac{\text{Output Power}}{\text{Input Power}} \times 100 .$$

www.expertguidance.co.uk
mahima.laroyia@expertguidance.co.uk
+447448352272

NEXT STEP



CHECK SPECIFICATION



EXAM QUESTIONS ON THIS TOPIC

www.expertguidance.co.uk
mahima.laroyia@expertguidance.co.uk
+447448352272