

Q1. A student investigated the temperature change when zinc reacts with copper sulfate solution.

The student used a different concentration of copper sulfate solution for each experiment.

The student used the apparatus shown below.

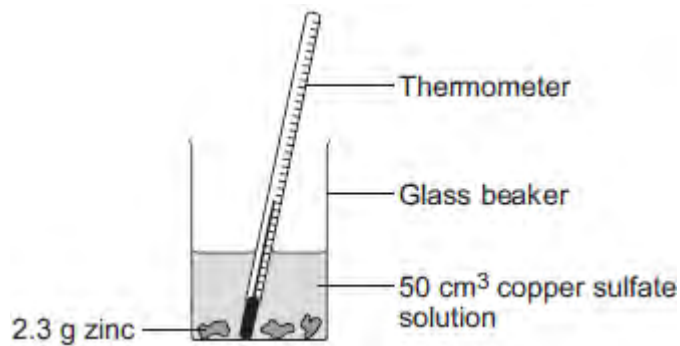

The student:

- measured 50 cm³ copper sulfate solution into a glass beaker
- measured the temperature of the copper sulfate solution
- added 2.3 g zinc
- measured the highest temperature
- repeated the experiment using copper sulfate solution with different concentrations.

The equation for the reaction is:



(a) The thermometer reading changes during the reaction.

Give **one** other change the student could **see** during the reaction.

.....
.....

(1)

(b) Suggest **one** improvement the student could make to the apparatus.

Give a reason why this improves the investigation.

Improvement

.....
Reason

.....

(2)

- (c) **In this question you will be assessed on using good English, organising information clearly and using specialist terms where appropriate.**

The student's results are shown in the table.

Table

Experiment number	Concentration of copper sulfate in moles per dm³	Increase in temperature in °C
1	0.1	5
2	0.2	10
3	0.3	12
4	0.4	20
5	0.5	25
6	0.6	30
7	0.7	35
8	0.8	35
9	0.9	35
10	1.0	35

Describe **and** explain the trends shown in the student's results.

.....
.....
.....
.....

.....

.....

.....

.....

.....

.....

(6)
(Total 9 marks)

Q2. A student investigated displacement reactions of metals.

The student added different metals to copper sulfate solution and measured the temperature change.

The more reactive the metal is compared with copper, the bigger the temperature change.

The apparatus the student used is shown in **Figure 1**.

Figure 1

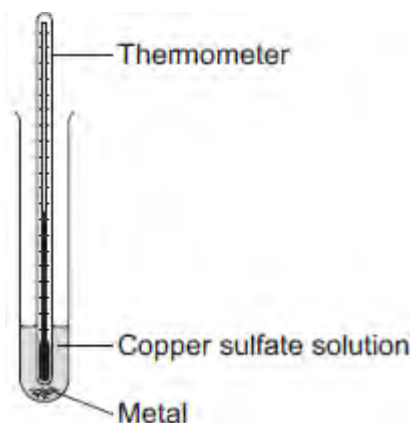

(a) State **three** variables that the student must control to make his investigation a fair test.

1

2

3

(3)

(b) **Figure 2** shows the thermometer in one experiment before and after the student added a metal to the copper sulfate solution.

Figure 2

Before adding metal

After adding metal

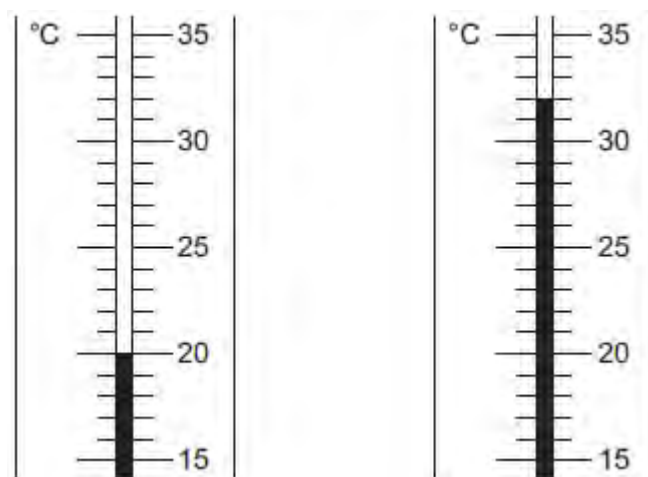

Use **Figure 2** to complete **Table 1**.

Table 1

Temperature before adding metal in °C
Temperature after adding metal in °C
Change in temperature in °C

(3)

- (c) The student repeated the experiment three times with each metal.

Table 2 shows the mean temperature change for each metal.

Table 2

Metal	Mean temperature change in °C
Cobalt	4.5
Gold	0.0
Magnesium	10.0
Nickel	3.0
Silver	0.0

Tin	1.5
-----	-----

(i) On **Figure 3**, draw a bar chart to show the results.

Figure 3

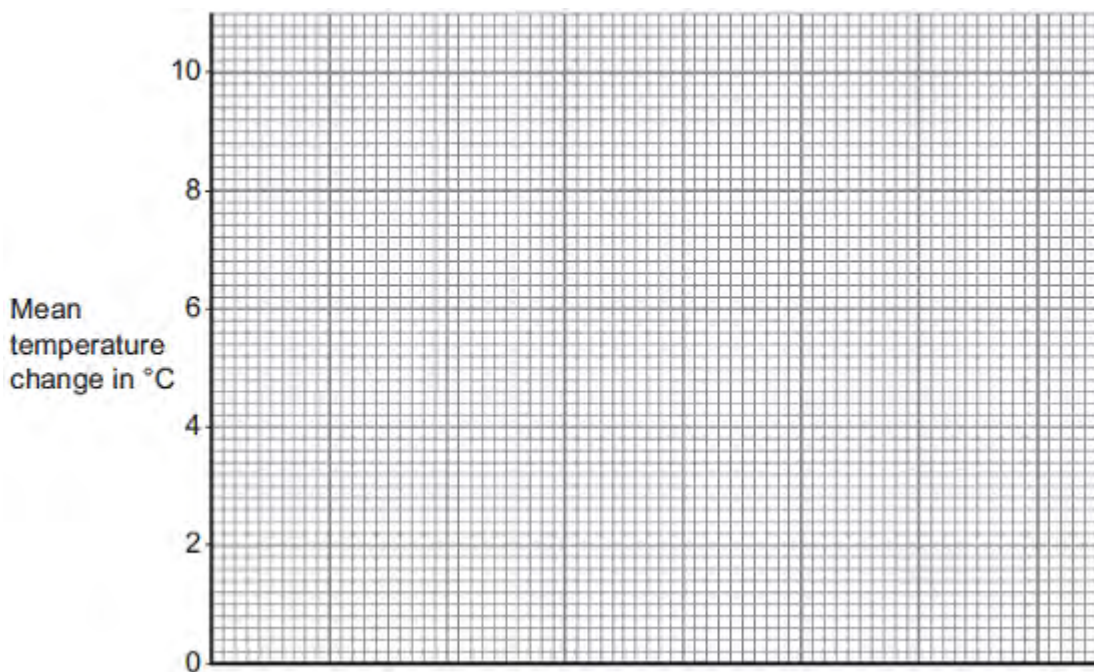

(3)

(ii) Why is a line graph **not** a suitable way of showing the results?

.....

(1)

(iii) Use the results to work out which metal is the most reactive.

Give a reason for your answer.

Most reactive metal

Reason

.....

(2)

(iv) Explain why there was no temperature change when silver metal was added to the copper sulfate solution.

.....
.....
.....
.....

(2)

(v) It is **not** possible to put all six metals in order of reactivity using these results.

Suggest how you could change the experiment to be able to put all six metals into order of reactivity.

.....
.....
.....
.....
.....

(2)

(Total 16 marks)

Q3.Metals are extracted from their ores.

Many copper ores contain only 2% of copper compounds.

(a) Copper is now extracted from ores containing a low percentage of copper compounds.

Suggest **two** reasons why.

.....

.....

.....

.....

(2)

(b) Chalcocite, an ore of copper, contains copper sulfide.

The flow diagram shows how copper metal is extracted from chalcocite.

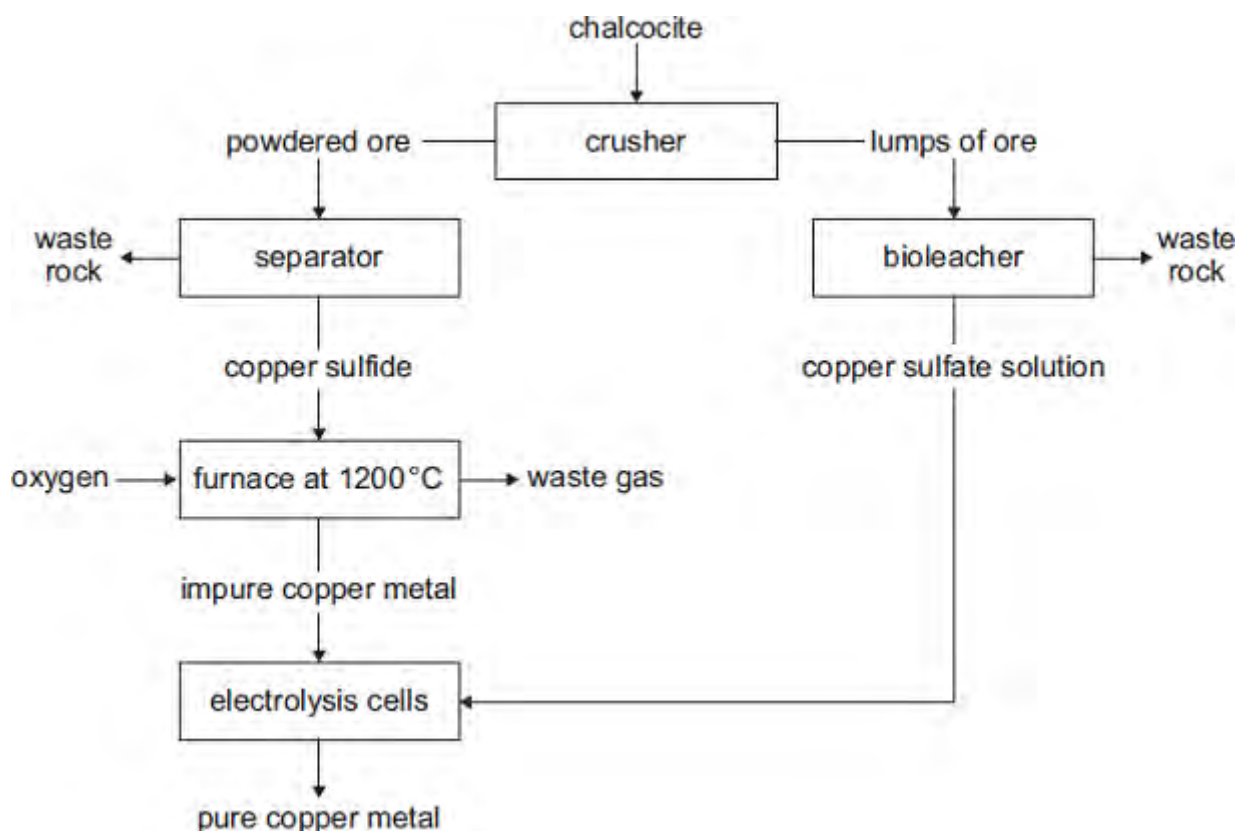

(i) Suggest **one** reason why it is difficult to dispose of the waste rock.

.....
.....

(1)

- (ii) The reaction in the furnace could cause environmental pollution.
Explain how.

.....
.....
.....
.....

(2)

- (iii) The extraction of pure copper is expensive.
Give **one** reason why.

.....
.....

(1)

- (iv) Pure copper is produced by electrolysis of copper sulfate solution.

Which electrode do the copper ions move towards?
Give a reason for your answer.

.....
.....
.....
.....

(2)

- (v) Large areas of land are contaminated with copper compounds.
Phytomining can be used to remove these copper compounds from the land.

What is used in phytomining to remove copper compounds from the land?

.....
.....

(1)
(Total 9 marks)

Q4. Lithium is in Group 1 of the periodic table.

Lithium reacts with water to produce a gas and an alkaline solution.

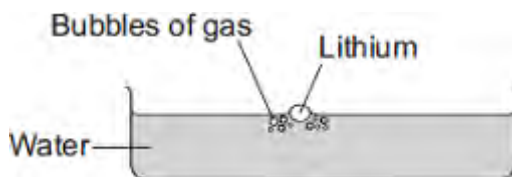

(a) (i) Name the gas produced.

.....

(1)

(ii) Which ion causes the solution to be alkaline?

.....

(1)

(b) Potassium is also in Group 1 of the periodic table.
Potassium reacts with water in a similar way to lithium.

Write down **two** differences you would see between the reactions of potassium and lithium with water.

1

.....

2

.....

(2)
(Total 4 marks)

Q5.Cans for food and drinks are made from steel or aluminium.The main metal in steel is iron.



By Sun Ladder (Own work) [CC-BY-SA-3.0 or GFDL],
via Wikimedia Commons

(a) Iron is extracted by heating a mixture of iron oxide and carbon in a blast furnace.

(i) Name this type of reaction.

.....

(1)

(ii) Balance the symbol equation for this reaction.

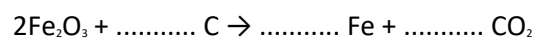

(1)

(b) Aluminium ore, bauxite, contains aluminium oxide, iron oxide and silicon dioxide. Aluminium is extracted by electrolysis of aluminium oxide.

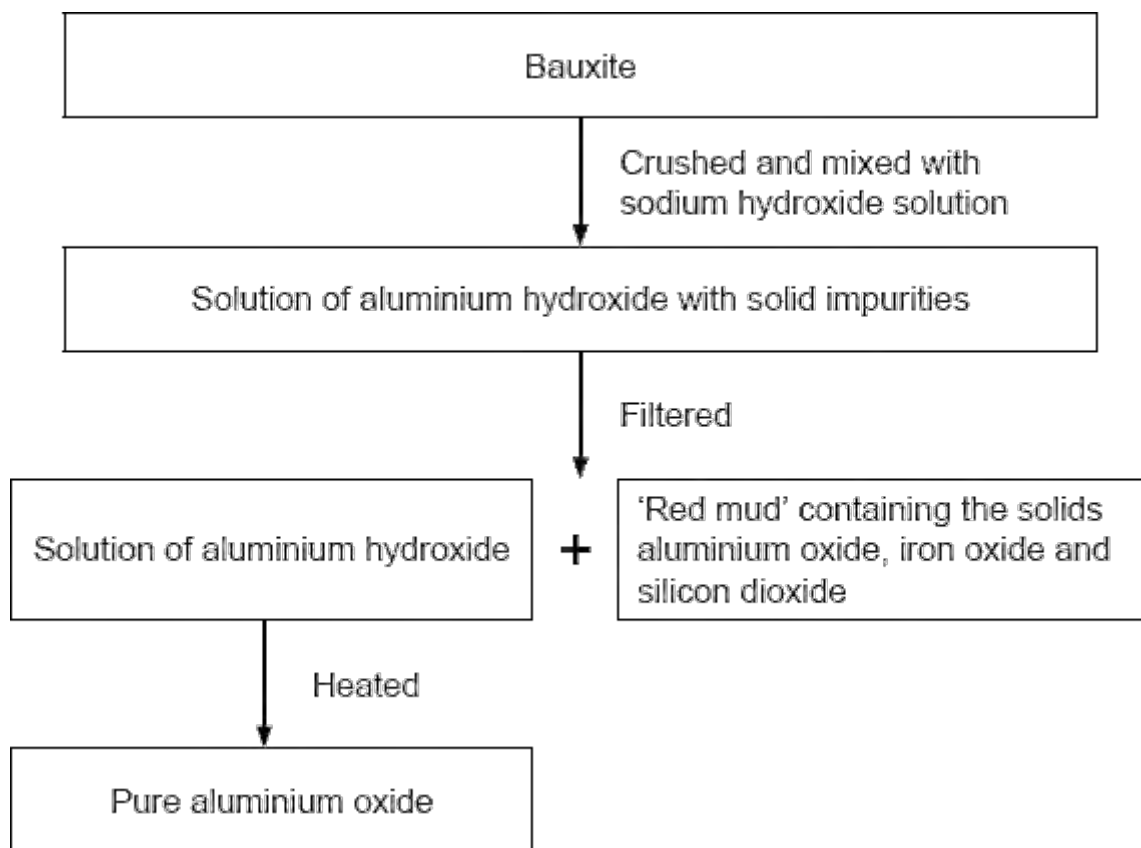

The 'red mud' which is dumped in very large ponds contains:

Name of solid	Percentage (%)
Aluminium oxide	10
Iron oxide	65
Silicon dioxide	25

- (i) 100 tonnes of bauxite produced 50 tonnes of pure aluminium oxide and 50 tonnes of 'red mud'.

What percentage of aluminium oxide did the bauxite contain?

.....

Answer = %

(1)

(ii) Apart from the solids shown in the table, name **one** other substance that would be in the 'red mud'.

.....

(1)

(iii) The purification of the aluminium oxide is usually done near to the bauxite quarries. Suggest **one** reason why.

.....

(1)

(c) Aluminium is used to make many things including cans.

During one year in the USA:

- 100 billion aluminium cans were sold
- 55 billion aluminium cans were recycled.

Give **one** environmental impact of recycling aluminium cans and **one** ethical or social impact of recycling aluminium cans.

Environmental

.....

Ethical or social

.....

(2)
(Total 7 marks)

Q6. Read the information.

Alumina is a white solid. In 1800, scientists thought that alumina contained an undiscovered metal. We now call this metal aluminium. At that time, scientists could not extract the aluminium from alumina.

In 1825, Christian Oersted, a Danish scientist, did experiments with alumina.

Step 1 He reacted a mixture of hot alumina and carbon with chlorine to form aluminium chloride. The reaction is very endothermic.

Step 2 The aluminium chloride was reacted with potassium. He was left with potassium chloride and tiny particles of aluminium metal.

Other scientists were **not** able to obtain the same results using his experiment and his work was not accepted at that time.

In 1827, Friedrich Wöhler, a German chemist, made some changes to Oersted's experiment. He obtained a lump of aluminium. He tested the aluminium and recorded its properties.

(a) Suggest why scientists in 1800 could not extract aluminium from alumina.

.....
.....

(1)

(b) Oersted's experiment in 1825 was **not** thought to be reliable.

Explain why

.....
.....

(1)

(c) Why must the reaction in **Step 1** be heated to make it work?

.....
.....

(1)

(d) Complete the word equation for the reaction in **Step 2**.

aluminium + potassium → +
chloride m

(1)

(e) Suggest how Wöhler was able to prove that he had made a new metal.

.....
.....
.....
.....

(2)

(Total 6 marks)

Q7. Steels are used to make cars, bridges and knives.
The main element in steel is iron.

(a) Iron is extracted from an *ore* that contains about 60% iron oxide, Fe₂O₃

(i) What is the meaning of *ore*?

.....
.....

(1)

(ii) In a blast furnace, iron oxide reacts with carbon monoxide to produce iron.
The word equation for this reaction is:

iron oxide + carbon monoxide → iron + carbon dioxide

Complete and balance the chemical equation for this reaction.

Fe₂O₃ + CO → +

(2)

(iii) Name the type of reaction that produces a metal from its metal oxide.

.....

(1)

(b) Steels are produced from molten iron in two stages:

Stage 1 blowing oxygen into molten iron from the blast furnace.

Stage 2 adding other metals to make different steels.

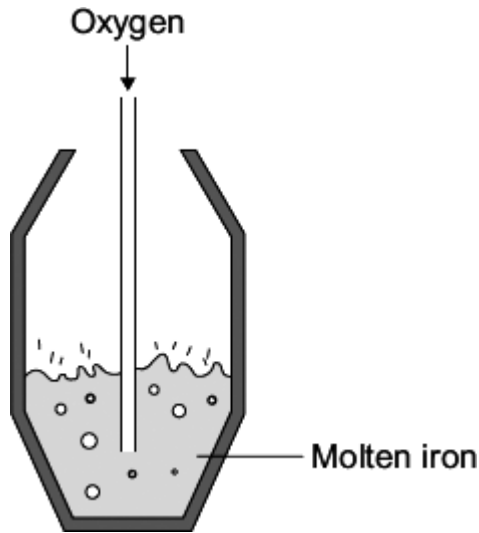

- (i) In **Stage 1**, suggest how the oxygen removes most of the carbon from the molten iron.

.....

.....

.....

.....

(2)

- (ii) **Stage 2** produces different steels.

Suggest why different steels are needed.

.....

.....

(1)

- (c) Old 5p and 10p coins in the UK were made from cupro-nickel.
Cupro-nickel is 75% copper and 25% nickel.

New 5p and 10p coins in the UK are now made from nickel-plated steel and not from cupro-nickel.

Explain why.

.....

.....
.....
.....

(2)
(Total 9 marks)